



# ALL POWER LABS

---

PERSONAL SCALE POWER



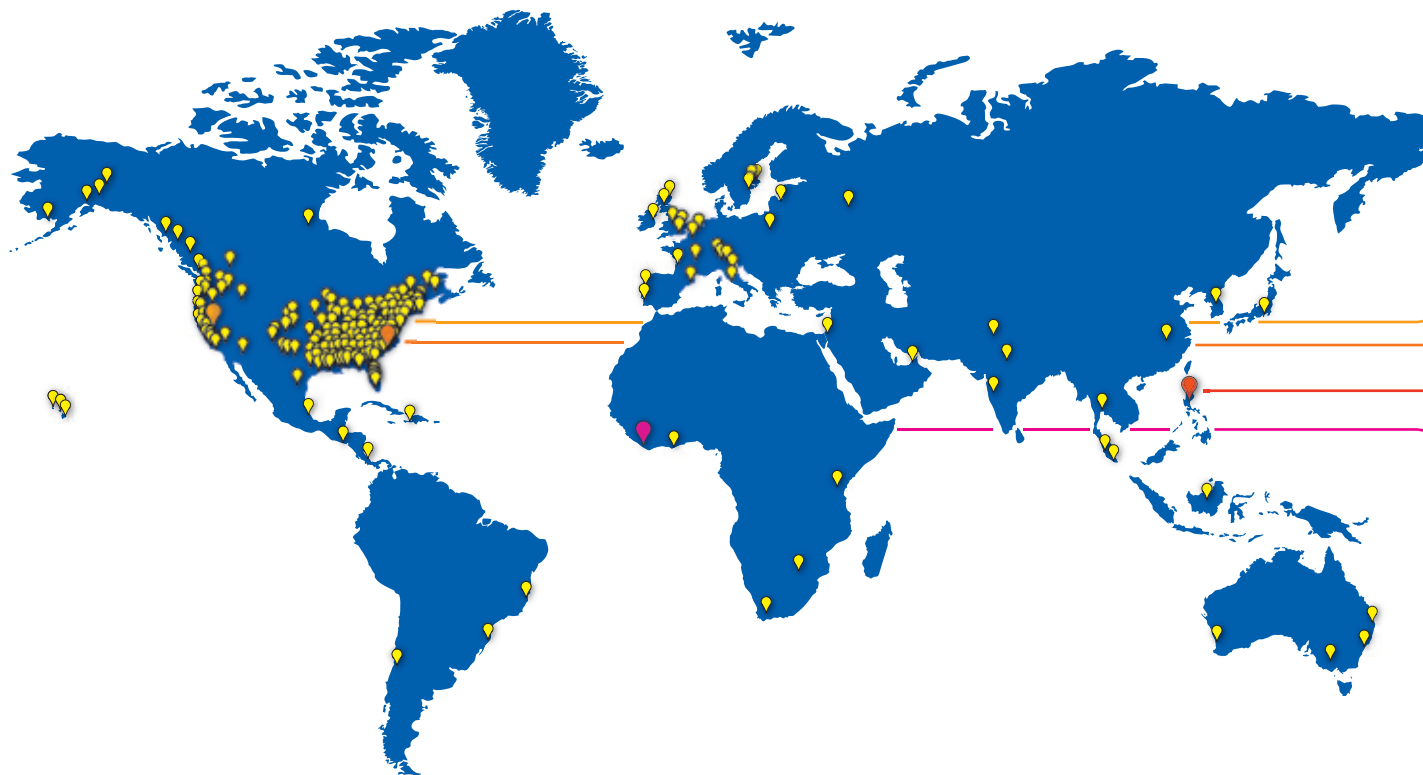

### University Education

Over 45 Universities use our GEK systems, including University of Minnesota.



### Research Institutions

US Dept. of Agriculture, US Dept. of Energy, Volcani Institute, and others.



### Rural Electrification

Off-grid sustainable communities like Tuwà are powered by GEK gasifiers.



### Developing World Energy

EcoPower Liberia in West Africa brings APL products to the developing world.

**ALL Power Labs** is the global leader in small-scale gasification. We make biomass gasifiers that are **ready for everyday use** and serve real world distributed energy needs.

Our project began in 2008 with the open source Gasifier Experimenters Kit (GEK) for research and education. It has since evolved into the GEK Power Pallet - a fully **automated solution for biomass power generation**.

Today you can find our 300+ GEKs and GEK Power Pallet systems in over 30 countries, and we are supporting research at over 45 universities.

## INDEX OF INFO

GEK® Power Pallet™	Page 4-9
Use Cases, Benefits & ROI	Page 10-11
GEK® & TOTTI™	Page 12-13
Research Equipment & Instrumentation	Page 14-15
Biochar Experimenters Kit (BEK™)	Page 16-17
About ALL Power Labs & Workshops	Page 18-19





### The Full Solution

The GEK Power Pallet is a **complete biomass power generation solution** that converts woody biomass to electricity, heat, and PTO shaft power. It is a compact and fully automated system delivered at the breakthrough price of \$1 to \$2 per watt.

Power Pallets are available in 10 kW and 20 kW sizes using Kubota and GM industrial engines paired with Mecc Alte AVR generators. The resulting combination delivers stable electricity from biomass at 120/208/240 VAC, 60 Hz or 50 Hz, in single, split, or three phase.

### Why It's Different

The GEK Power Pallet is distinguished by its ease of use, compact size, and affordable price. It is a solution that delivers the **hands-off operation** expected from modern power generation equipment.

These advantages are the result of breakthroughs in electronic control and waste heat recycling. An onboard microcontroller provides the expertise usually required from a trained operator. A multi-stage gasification architecture, combined with an innovative gasifier-engine thermal integration, significantly improves tar conversion and fuel flexibility (see page 13 for more information).

The result is a compact and technically advanced gasification solution that is **practical for everyday use**.



The **GEK Power Pallet** consists of a multi-stage gasifier, spark fired industrial engine, generator head, and Process Control Unit (PCU). The PCU monitors and responds to all internal reactor, engine, and filter conditions, displaying the results on an LCD screen.

The PCU also automatically adjusts the syngas/air mixture via a wide band Bosch oxygen sensor and shakes the ash grate when required by reactor conditions.

**PCU:** Automated control system, oxygen sensor, syngas/air adjustment, and ash grate shaker.

**Engine:** The Power Pallet is powered by:

- 10 kW - Kubota 3-cyl 962cc
- 20 kW - GM 4-cyl 3.0L

**Genhead:** 10 kW or 20 kW Mecc Alte industrial generator with automatic voltage regulation (AVR). 12 wire gen head is reconfigurable on-site to 120/208/240 VAC, 50 Hz or 60 Hz, in single, split, or three phase.

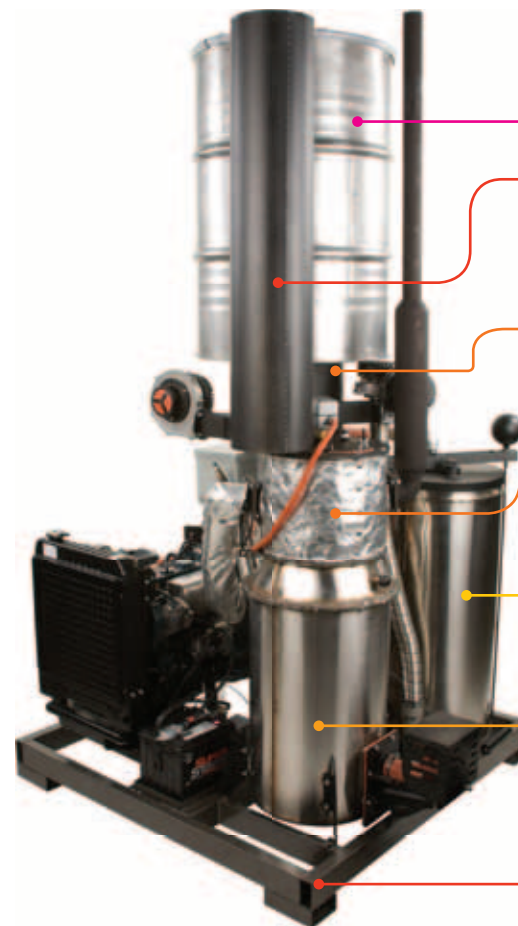
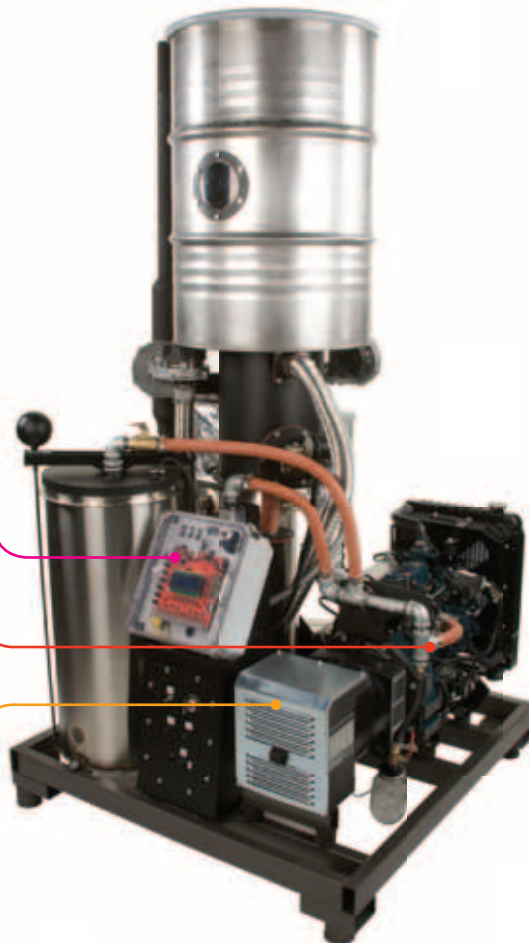

**Hopper:** Stainless steel hopper holds up to 10 hours of fuel.

**Flare:** Premixed swirl burner ensures clean start-up.

**TOTTI:** Waste heat recovery and recirculation system for improved tar cracking and moist fuel tolerance.

**Gas Filter:** Packed bed filter with washable foam elements.

**GEK Gasifier:** Compact multi-stage downdraft gasifier system that produces clean gas.

**Skid Base:** All components come mounted to a forklift-ready skid.

GEK POWER PALLET SPECS	10 kW	20 kW
Power Output	3-10 kW	5-20 kW
Biomass Consumption	12 kg / 26 lbs per hour at 10 kW	22 kg / 50 lbs per hour at 20 kW
Fuel Moisture Tolerance	Up to 30%	Up to 30%
Shipping Dimensions	1.2m x 1.2m x 1.8m 48" x 48" x 72"	1.2m x 1.3m x 1.8m 51" x 52" x 72"
Weight	499 kg / 1100 lbs	658 kg / 1450 lbs





Kubota

10kW

#### Kubota DG 972

Kubota engines have a well earned reputation for high reliability and extreme longevity in a wide variety of applications. Robust performance and compact footprint have made them the engine of choice for small scale industrial, agricultural, and generator applications.

This 962cc 3-cylinder inline gaseous fuel engine is based on the company's acclaimed diesel engines. The new combustion chamber, designed exclusively for the gaseous fuel engine, reduces emissions and the raised compression ratio increases efficiency.



20kW

#### GM Vortec 3.0 L I-4

The Vortec 3.0 L inline 4-cylinder engine is produced exclusively for industrial and marine applications. It has the longest production history of any GM Powertrain industrial engine, with a well-earned reputation for durability and reliability. The engine comes factory configured for gaseous fuels, with features including:

- Increased compression ratio
- Sintered powder metal exhaust valve seat inserts for enhanced durability
- Nodular iron crankshaft for increased strength and durability

Gasifying **1 kg of biomass**

produces about **2 m<sup>3</sup> of gas**

which produces about **1 HP-hr**

equivalent to about **0.75 kWh**

The best fuel for the GEK gasifier is chunky, dry, carbon-dense woody biomass. Fuels such as wood chips, wood chunks, nut shells, and coconut shells ranging in size from 0.5" to 2" (10mm to 50mm) are ideal.

FUEL TYPE	WILL IT WORK	HOW WELL	COMMENTS
Hardwood Chips	Yes	Excellent	1/4" to 2" (10mm – 50mm) chips
Softwood Chips	Yes	Excellent	1/4" to 2" (10mm – 50mm) chips
Nut Shells	Yes	Excellent	Needs least preparation
Coconut Shell	Yes	Excellent	Broken into chunks
Coffee Grounds	Yes	Fair	Pelletized
Sawdust	Yes	Fair	Pelletized
Corn Cobs	Yes	Fair	Broken into chunks
Manure	Yes	Fair	Dried to 30% moisture
Rice Husks	No		Under development
Straw	No		Under development
Sugar Cane Bagasse	No		Under development
Corn Stover	No		Under development
Poultry Litter	No		Under development

We do not currently recommend using any of the following fuels with our gasification systems: MSW, tires, medical waste, and coal.



The **GEK Power Pallet** provides reliable, low-cost electricity anywhere biomass is available.

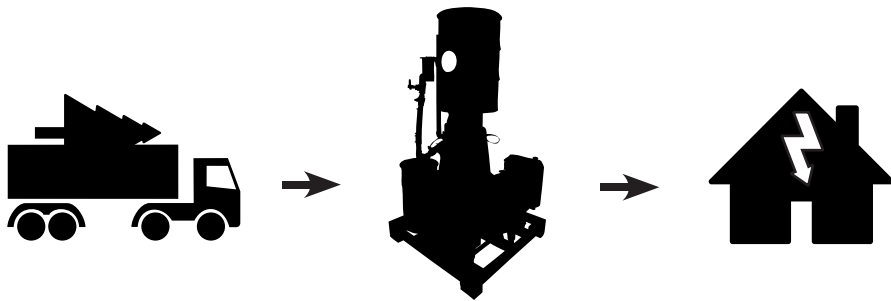

IDEAL USES AND INDUSTRIES	
Small Businesses	Forestry
Rural Electrification and Microgrids	Off-Grid Homes
Cell Towers, Radio Station Operators	Pumps, Wells, and Boreholes
Food Processors	Hospitals and Clinics
Commercial Refrigeration	Colleges and Universities
Agriculture	Energy Research

**Renewable Clean Energy**

Biomass gasification is a clean, carbon neutral method of producing electricity. When gasification is coupled with biochar production, the process becomes carbon negative. Biochar is a highly beneficial soil amendment that can sequester carbon for hundreds to thousands of years.

**Affordable**

The GEK Power Pallet is one of the most affordable renewable energy systems on the market and delivers attractive ROI without economic subsidies. At just \$1.50 to \$2.25 per watt, the capital cost of our system is 80% less expensive than comparable solar or wind power systems.

**Simple to Use and Maintain**

The GEK Power Pallet is the first system of its kind that makes gasification easy and user-friendly. We provide a range of training videos and manuals to get you up and running quickly. In addition, our systems are easy to service and can be maintained by most engine or generator mechanics.

**Low Cost Electricity**

Electricity can be generated from biomass for as low as US \$0.02 per kWh. Generating power with diesel is dramatically more expensive. The cost of obtaining power with solar or wind is often prohibitively expensive without subsidies.

FUEL PRICE COMPARISON	
Fuel	Price Range
Diesel	\$0.35 - 0.50 kWh
Biomass	<b>\$0.02 - 0.05 kWh</b>

**Low Biomass Demand**

The GEK Power Pallet is designed at a scale that allows individual users to easily source biomass fuel locally and sustainably. This feature allows for easy operation and management without dependence on large-scale biomass supply chains, thus enabling operation in remote locations and developing countries.

	BIOMASS FUEL CONSUMPTION			
	10 kW Engine (@ 75% load)		20 kW Engine (@ 75% load)	
	Biomass Weight	Power Output	Biomass Weight	Power Output
1 Hour	9 kg	7.5 kWh	18 kg	15 kWh
8 Hours	72 kg	60 kWh	144 kg	120 kWh
24 Hours	216 kg	180 kWh	432 kg	360 kWh

**Note: 1.2 kg biomass is roughly equal to 1 kWh electrical output**

**Electricity in Remote Areas**

The GEK Power Pallet uses locally available fuel. Unlike diesel, agricultural and forest wastes are readily available and do not require shipping over long distances.



## Gasifier Experimenters Kit (GEK®)

The basic GEK kit includes all components needed for a full gasification system. Included is a gas making reactor, stainless steel hearth, fuel hopper, gas cowling and ash handling system, cyclone, packed bed filter, ejector venturi gas pump, fuel/air mixer, swirl burner, and instrumentation. The GEK will **quickly get you over the starting hurdles of gasification** and on to the more rewarding work of making clean tar-free gas.



### Level III: You Weld

The GEK as a ready-to-weld kit. Includes all the rolled tubes, flange rings, and end plates needed to make all vessels, as well as plumbing and accessory parts to complete the full GEK gasifier system.

### Level IV: You Assemble

Arrives at your door with fabrication complete, ready for you to assemble and run. Assembly is minor, requiring only basic wrench turning and plumbing. No welding or other metal work is required.

## Tower Of Total Thermal Integration (TOTTI™)

The Hot TOTTI is comprised of the Auger Feed Drying Bucket and Pyrocoil. This combination demonstrates a powerful new method to **recover waste heat** from hot output syngas and IC engine exhaust and **return it to the gasifier to do useful work**. The result is higher combustion temperatures for improved tar conversion, increased tolerance for high moisture fuels, and increased gasifier efficiency. Hot TOTTI components are available as add-ons to either of the basic GEK kits.

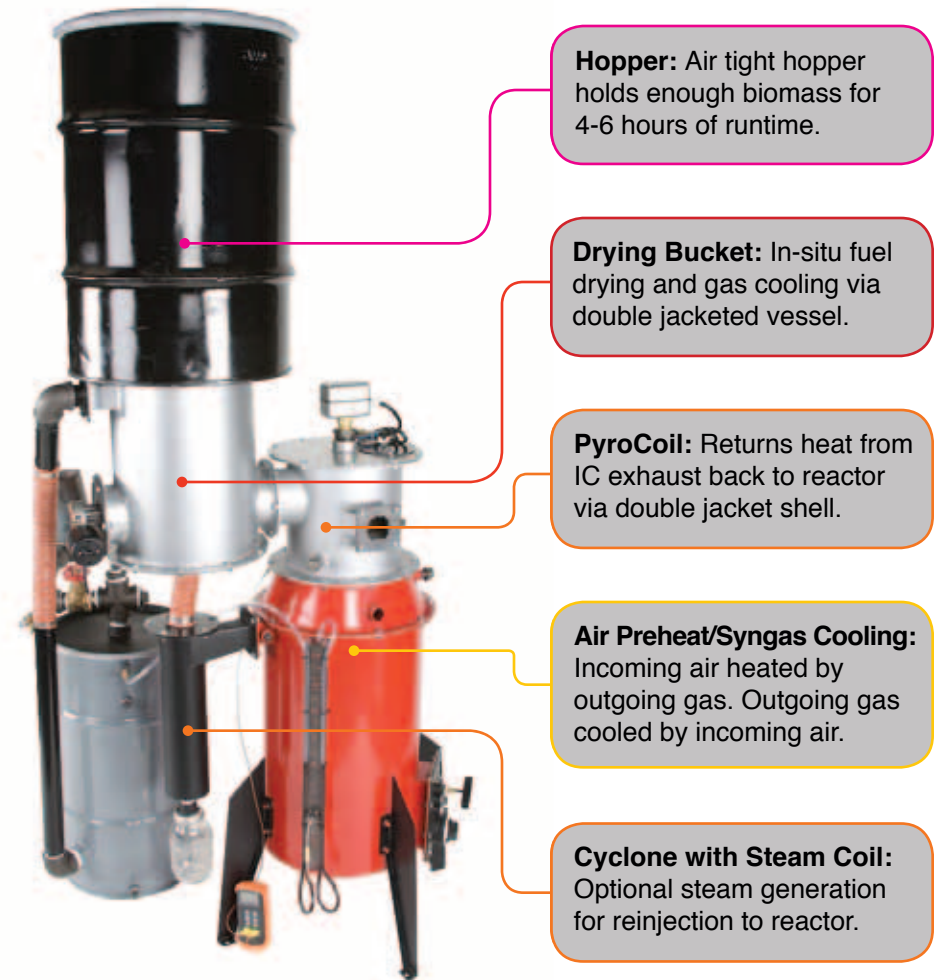

### GEK Process Control Unit (PCU)

The PCU is an Arduino-based, open source sensing and control board with an Atmel AVR ATmega1280 processor. The board is specifically designed for the types of instrumentation and automation requirements of biomass thermal conversion projects.

The board offers a generous number of thermocouple, pressure, analog signal, and frequency inputs, and an array of servo driver and high current PWM capable DC N-channel switched outputs. Networking to other devices is supported via USB, serial, SD card, and CANbus (the networking standard for engine systems).

The PCU is ideal for applications which require integrated instrumentation, datalogging and control.



### Research Instrumentation Kit

The Research Instrumentation Kit includes all the basic temperature, pressure, flow, and tar testing accessories needed for gasification research and teaching. The following accessories are compatible with data input ports on the PCU.

Tar Testing	Temperature
Colorimeter to measure tar concentration	(6) K-type 24" point probe thermocouples
Pump, filter, and filter holder for gas sampling	(10) K-type hard probe thermocouples (6", 12", 24")
(100) Filter discs	Fittings and bushings for TC mounting
(100) Vials for tar dissolution	
Flow Rate	Pressure
(2) Calibrated orifice flow meters (air in, gas out)	Barbs and plumbing to connect PCU to tap points
Proportional servo valve to control gasifier flow rate	Silicone tubing
Silicone tubing, barbs and plumbing	

### Portable Infrared Gas Analyzers

The Gasboard 3100 (online, rack mounted) and Gasboard 3100P (portable) infrared gas analyzers can be used to measure the concentration of up to 6 gases such as CO, CO<sub>2</sub>, CH<sub>4</sub>, H<sub>2</sub>, C<sub>n</sub>H<sub>m</sub>, and O<sub>2</sub> with a precision of 0.01% and accuracy of ±1-2%. It will also automatically calculate the caloric value of the gas. These analyzers are typically used for gas analysis in biomass or coal gasification, steel production blast furnaces, and coking.

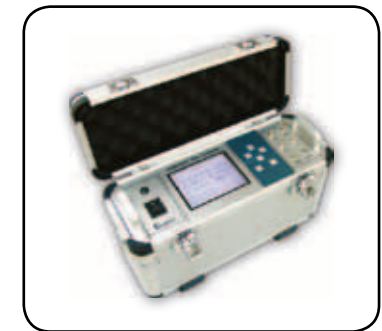
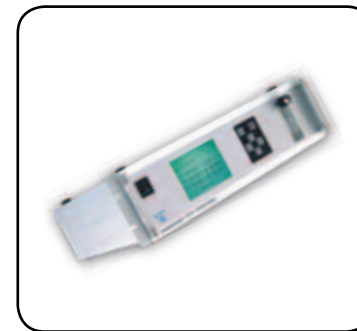

FEATURES (V3.02)	FULL FILL	LITE FILL
Processor	Atmel ATmega 1280	
Thermocouple Inputs	16 K-type	4 K-Type
High/Low Pressure Inputs ( $\pm 28"/8" H_2O$ )	4/2	1/1
FET Outputs (5 A continuous)	8	4
Analog Inputs (10-bit, Phidgets connectors)	8	4
Frequency/Counter Input	1	0
R/C Hobby Servo Outputs	3	1
Display (4x20 Character)	YES	YES
4 Button Keypad	YES	YES
MicroSD Slot	YES	NO
CANbus Hardware	YES	NO
RS-232 Interface	YES	NO
Prototype/Expansion Area	YES	YES





**Currently Not In Production**

Email [gek@allpowerlabs.org](mailto:gek@allpowerlabs.org) for future BEK availability.

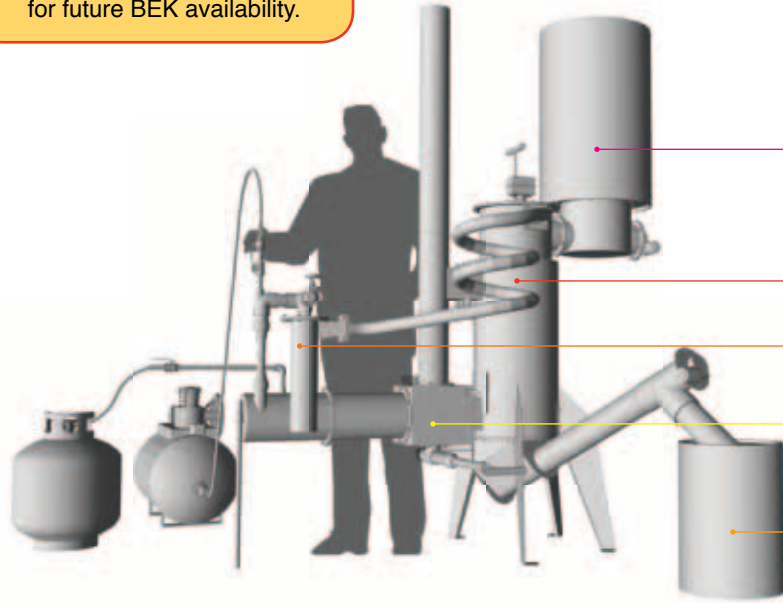
**Hopper**

55 gallon stainless steel hopper stores feedstock in an air and moisture tight environment.

**Reactor**

Vessel where feedstock is pyrolyzed in variable modes.

**Bio-Oil Condensing Circuit**

Optional component separates and collects tars produced from the pyrolysis process.

**Pyro Valve Box**

Allows users to choose between different pyrolysis modes, or mix them in real time.

**Char Hopper**

Collects and stores produced char in an air tight environment during cooling process.

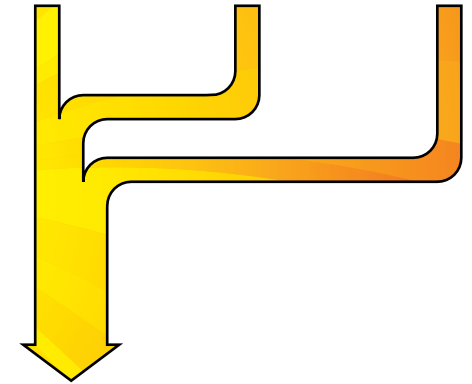
**The Biochar Experimenters Kit (BEK™)**

The BEK is a **multi-mode pyrolysis machine** for characterized biochar and bio-oil making. The BEK supports multiple pyrolysis process modes in direct combustion (updraft, TLUD, and stratified downdraft), indirect combustion retort, and sweep gas heat transfer.

The goal of the BEK is to provide a **flexible reactor platform for comparative biochar research**. A mixer box lets the user choose between the different modes or mix them in desired combinations. Temperature, residence time, and ramp rate can also be changed. Thermocouples are provided to monitor the results.

The BEK can be operated in either batch or continuous feed mode. An optional condensing circuit will separate bio-oil from the output gas. Clean combustion is ensured by a propane-assisted swirl burner and silicone nitride igniters.

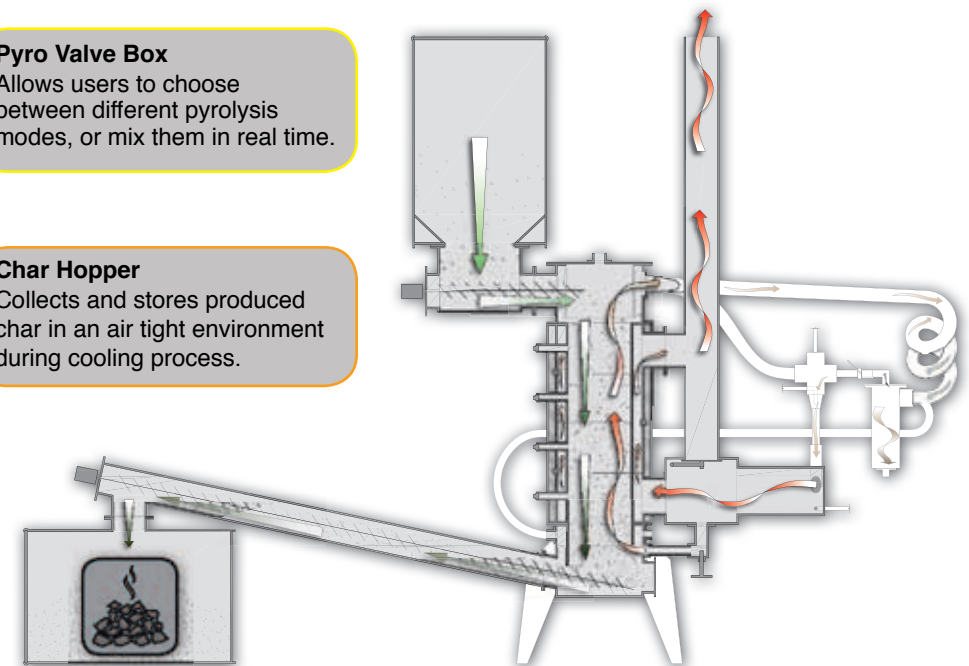

**ALL Power Labs** is the leading manufacturer of equipment for small-scale biomass gasification and a resource for open-source alternative energy solutions. Through GEK workshops hosted around the world, free online fabrication plans for individuals, and affordable ready-to-run systems, APL makes it easy for you to obtain high-performance solutions in small-scale gasification and pyrolysis.

The ALL Power Labs team is an unusual combination of DIY fabricators and university-trained scientists and engineers. The result is a powerful combination of technical ability and physical know-how for developing innovative energy solutions.



### Workshops

Each quarter, participants from around the world converge at ALL Power Labs to gain hands-on experience with the latest developments in gasification. Researchers, DIY enthusiasts, farmers, and development workers share experience and knowledge in a collaborative environment.

Whether you are a gasification expert or new to the technology, our workshops will get you past the technical hurdles of biomass thermal conversion and provide opportunities to learn more about reliable power generation or making biochar for soil amendment.





**ALL Power Labs**  
 1010 Murray Street - Berkeley, CA 94710  
 Phone: 510-845-1500 - Fax: 510-550-2837  
 www.gekgasifier.com

## 2011 Order Form

Show	
Taken By	
Sales Rep	

Affix Customer Card		Name	
<b>Shipping Information</b>		Company	
		Phone	
Address		Email	
City		Payment Method	
State, Zip		Ship Via	
Country		Notes	

Item	Description	Price	Quantity	Extension
<b>GEK® Power Pallets™</b>				
2910	10 kW GEK® Power Pallet	\$16,995		
2920	20 kW GEK® Power Pallet	\$25,995		

<b>Gasifier Experimenters Kits</b>				
2505	GEK® Level IV, Welded Ready to Assemble, Stainless Steel	\$2,995		
2501	GEK® Level III, Unwelded, Mild Steel	\$1,795		

<b>GEK® Add-ons - TOTTI™ Components (3500 + 3600 comprise the Hot TOTTI)</b>				
3500	Auger Feed Drying Bucket	\$1,395		
3600	Pyrocoil IC Exhaust Heat Recycle	\$1,195		

<b>Controls and Instrumentation</b>				
3700	PCU Full	\$1,395		
3701	PCU Lite	\$395		
3710	PCU NEMA Box Enclosure and Mounting Hardware	\$295		
3720	Research Instrumentation Package	\$2,395		
3100	Online Infrared Gas Analyzer	\$9,250		
3100-P	Portable Infrared Gas Analyzer	\$9,250		

Discount Code

<b>Sub Total</b>	
<b>Discount</b>	
<b>Shipping</b>	
<b>Total</b>	