



ALL Power Labs
personal scale power

Chapter 7

Generator



Table of Contents

Disclaimer

Generators

 Frequency

Wiring Configurations

 Series Star

 Parallel Star

 Series Delta

 Parallel Delta

 Double Delta

 1 Phase Zig-Zag

 Load Imbalance

Automatic Voltage Regulator (AVR)

 AVR Adjustment

Troubleshooting

Disclaimer

All electrical output connections are the responsibility of, and are at the discretion of, the end user. When making terminal connections, all cable and terminal lugs should meet the relevant standards of the country of final destination. It is recommended that power conditioning be used for the operation of sensitive equipment. ALL Power Labs is not responsible for any damages due to inappropriate wiring or output connections, variations in voltage, or otherwise. This document is to be used only as a general guide for technicians who have read and understand the installers manuals of the Mecc Alte generators. All configuration changes and connections to the generator should be performed by a qualified electrician in conformance with local electrical code. Please refer to the generator configuration documentation provided for specific wiring information.

Generators

The electric generator unit of the Power Pallet is a 6-winding alternator (AC generator). The generator can be wired in several configurations to produce 3-phase or split single phase current. The frequency of the alternating current produced by the generator is a function of engine speed.

	20PP/50Hz	20PP/60Hz
Model	MeccAlte NPE32 E/4 12-wire 4-Pole Generator	MeccAlte NPE32 E/4 12-wire 4-Pole Generator
Poles	4	4
Engine RPM	1500	1800

Note: The frequency stated on the generator nameplate may be different from the actual operating frequency. This is because the generators come with a standard stator unit that can operate at either 50Hz or 60Hz, even if the generator nameplate is indicated as 60Hz. Operating frequency is determined by governor setting.

Frequency

Two common frequencies of alternating current are used through most of the world are 50Hz and 60Hz. Because a significant amount of equipment is designed to use only one frequency or the other it is vital that the Power Pallet produce current at the correct frequency for the equipment that it will power.

The generator is driven synchronously with the engine, meaning the generator turns at the same

rate as the engine, and the frequency of the alternating current (AC) produced by the generator is a multiple of the engine speed. A 2-pole generator unit will produce current frequency that is the same as the engine speed; a 4-pole unit will produce current at twice the frequency of the engine speed. For example, a 2-pole generator driven by an engine at 1800 rotations per minute (RPM) is the same as a frequency of 30 Hertz

$$\frac{1800 \text{ rotations}}{1 \text{ minute}} \times \frac{1 \text{ minute}}{60 \text{ seconds}} \times 1 \text{ pair of poles} =$$

$$\frac{30 \text{ rotations}}{1 \text{ seconds}} \times 1 \text{ pair of poles} = 30\text{Hz AC current}$$

A 2-pole generator driven at 1800 RPM produces a 30hz AC current.

When a 4-pole generator is attached the AC frequency will be 60HZ:

$$\frac{1800 \text{ rotations}}{1 \text{ minute}} \times \frac{1 \text{ minute}}{60 \text{ seconds}} \times 2 \text{ pair of poles} =$$

$$\frac{30 \text{ rotations}}{1 \text{ seconds}} \times 2 \text{ pair of poles} = 60\text{Hz AC current}$$

A 4-pole generator driven at 1800 RPM produces a 60hz AC current.

The operating frequency of the Power Pallet is configured during production. The model PP20 Power Pallet can be converted between 50hz and 60hz by re-programming the electronic governor unit and adjusting the engine spark timing. See the engine section for details on performing these tasks.

Wiring Configurations

The generator's stator unit contains six independent windings. Each winding is wired to a numbered ring terminal at either end. To change the configuration of the generator, the terminals must be connected the appropriate studs on the terminal block inside the housing on the top of the generator. The Figures 1 (for 50Hz) and 2 (for 60Hz) below shows terminal connections for several common configurations. The tables following each figure list the voltages.

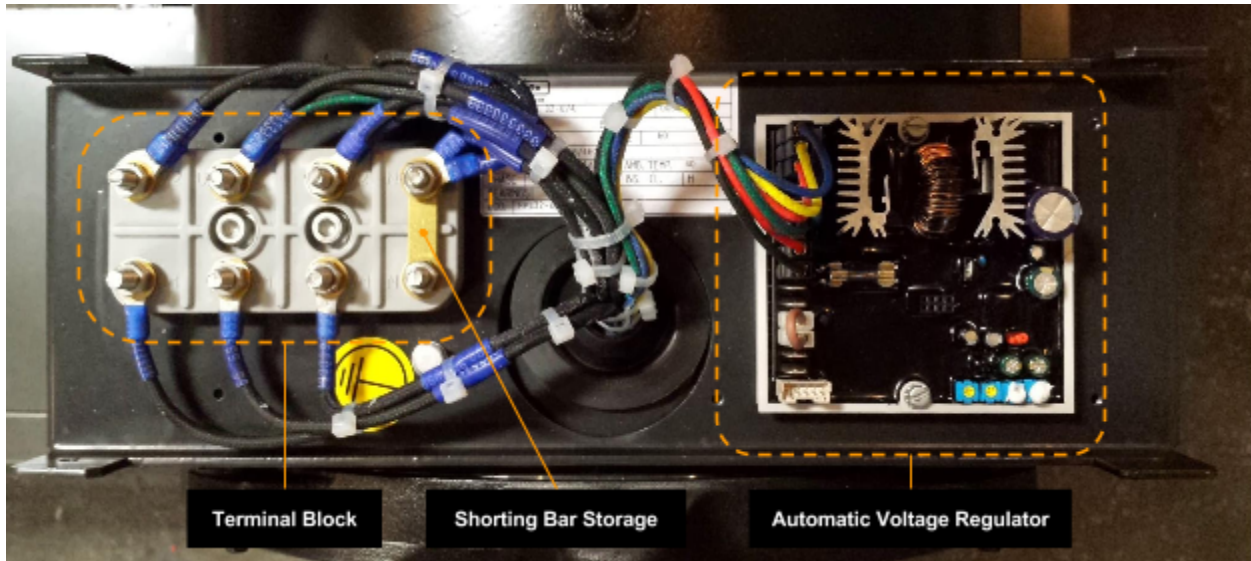

The terminal block and AVR (Automatic Voltage Regulator) are in the box above the generator.



In the photo of the terminal block shown above, observe that each of the terminals has a blue collar with numbers printed in white. The numbers indicate the number of each terminal, corresponding to the numbers in the diagrams on the following pages. The rear row has two terminals per bolt. The *shorting bars* (also known as *bridges* or *link bars*) are stored on the right-most pair of bolts. These may be used to configure the generator output according to any of the configurations on the following pages by shorting between the terminals as indicated on the terminal block diagrams.

Series Star

50Hz: 400 VOLT (L-L), 3 PHASE
 60Hz: 480 VOLT (L-L), 3 PHASE

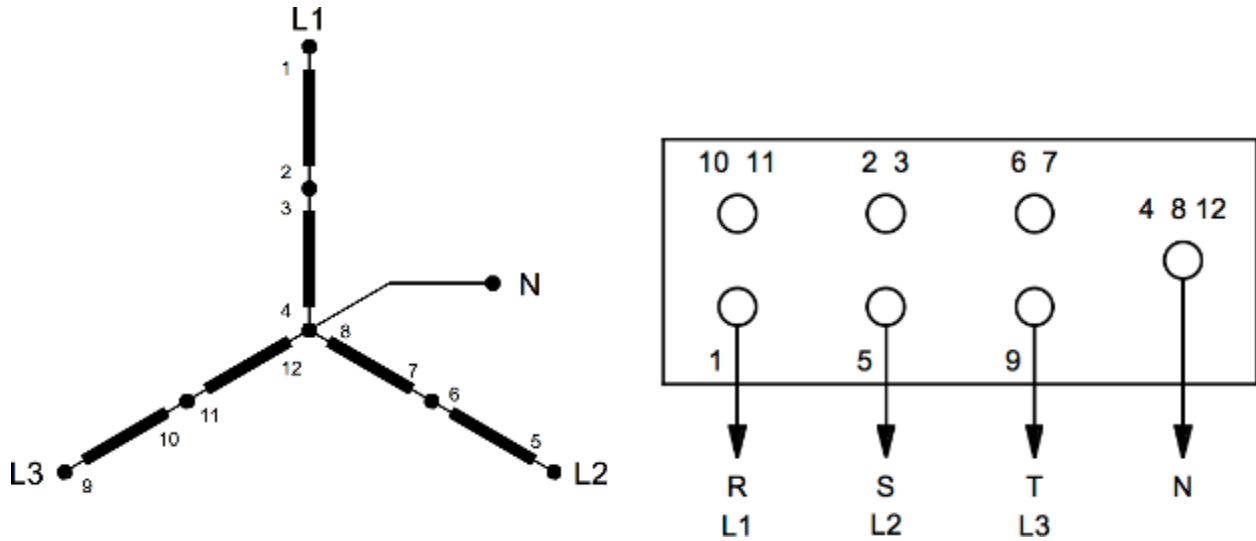

Legs	Voltages				
	50hz	380 3Φ	400 3Φ	415 3Φ	440 3Φ
L1-L2-L3	60hz	415 3Φ	440 3Φ	460 3Φ	480 3Φ
L-L	50hz	380	400	415	440
	60hz	415	440	460	480
N-L	50hz	220	230	240	254
	60hz	240	254	266	277

Parallel Star

50Hz: 200 VOLT, 3 PHASE; 115 VOLT, 1 PHASE
 60Hz: 208 VOLT, 3 PHASE; 120 VOLT, 1 PHASE

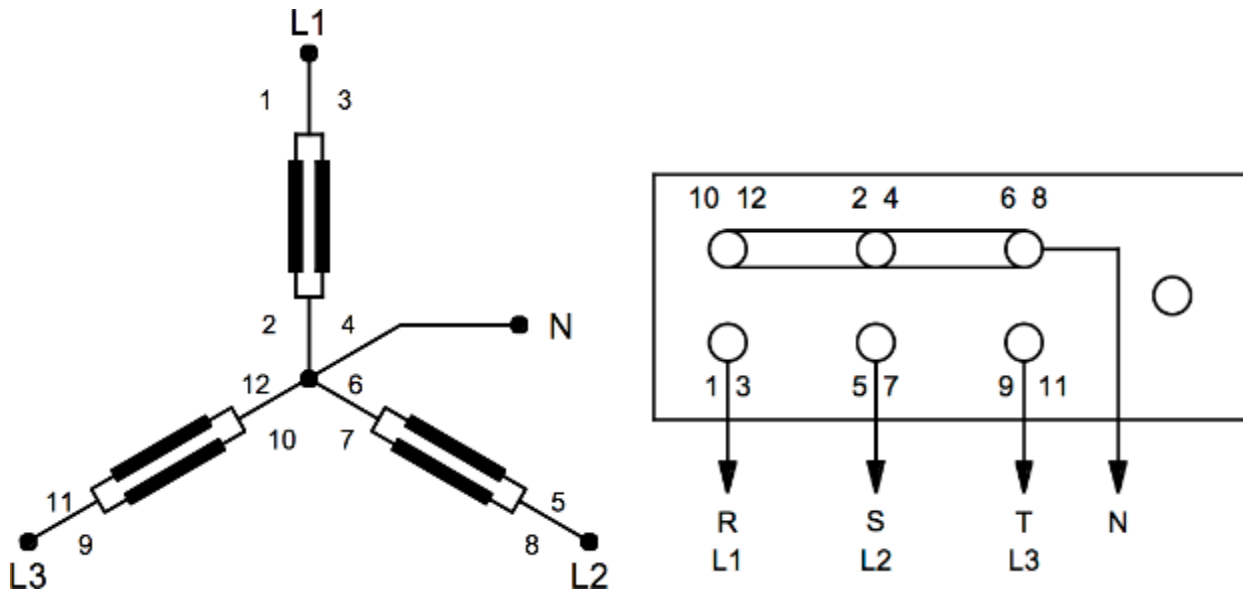

Legs	Voltages				
L1-L2-L3	50hz	190 3Φ	200 3Φ	208 3Φ	220 3Φ
	60hz	208 3Φ	220 3Φ	230 3Φ	240 3Φ
L-L	50hz	190	200	208	220
	60hz	208	220	230	240
N-L	50hz	110	115	120	127
	60hz	120	127	133	139

Series Delta

50Hz: 230 VOLT, 3 PHASE; 115/230 VOLT 1 PHASE
 60Hz: 240 VOLT, 3 PHASE; 120/240 VOLT 1 PHASE

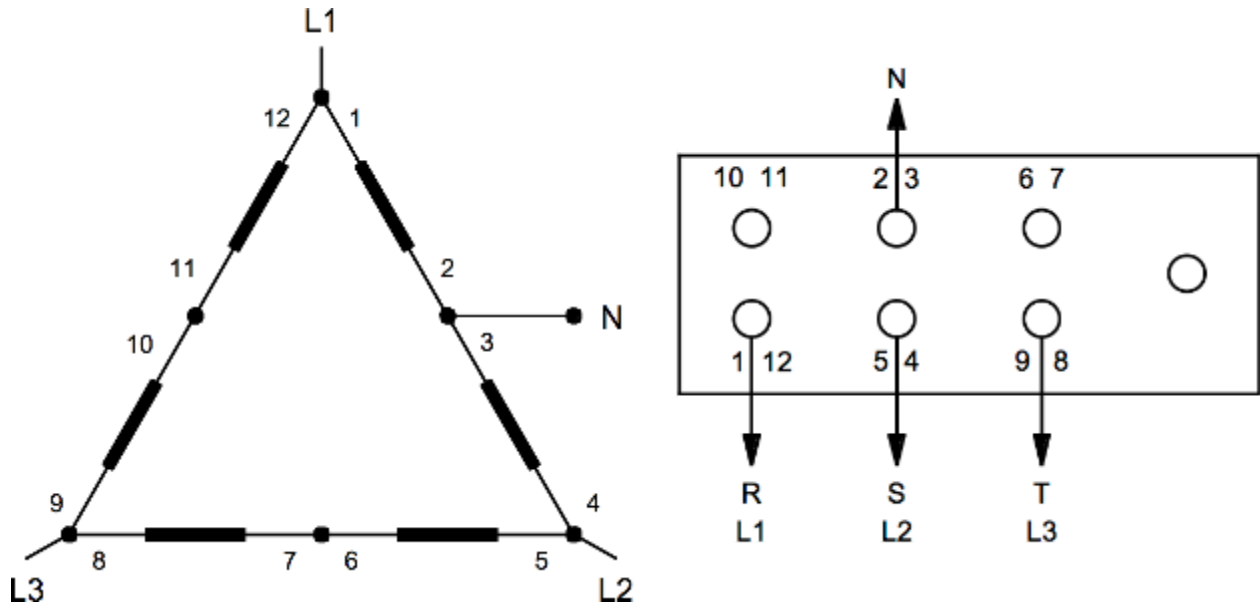

Legs	Voltages				
	L1-L2-L3	50hz	220 3Φ	230 3Φ	240 3Φ
60hz		240 3Φ	254 3Φ	266 3Φ	277 3Φ
L-L	50hz	220	230	240	254
	60hz	240	254	266	277
N-L	50hz	110	115	120	127
	60hz	120	127	133	139

Parallel Delta

50Hz: 115 VOLT, 3 PHASE; 115 VOLT, 1 PHASE (L1-L2)
 60Hz: 120 VOLT, 3 PHASE; 120 VOLT, 1 PHASE (L1-L2)

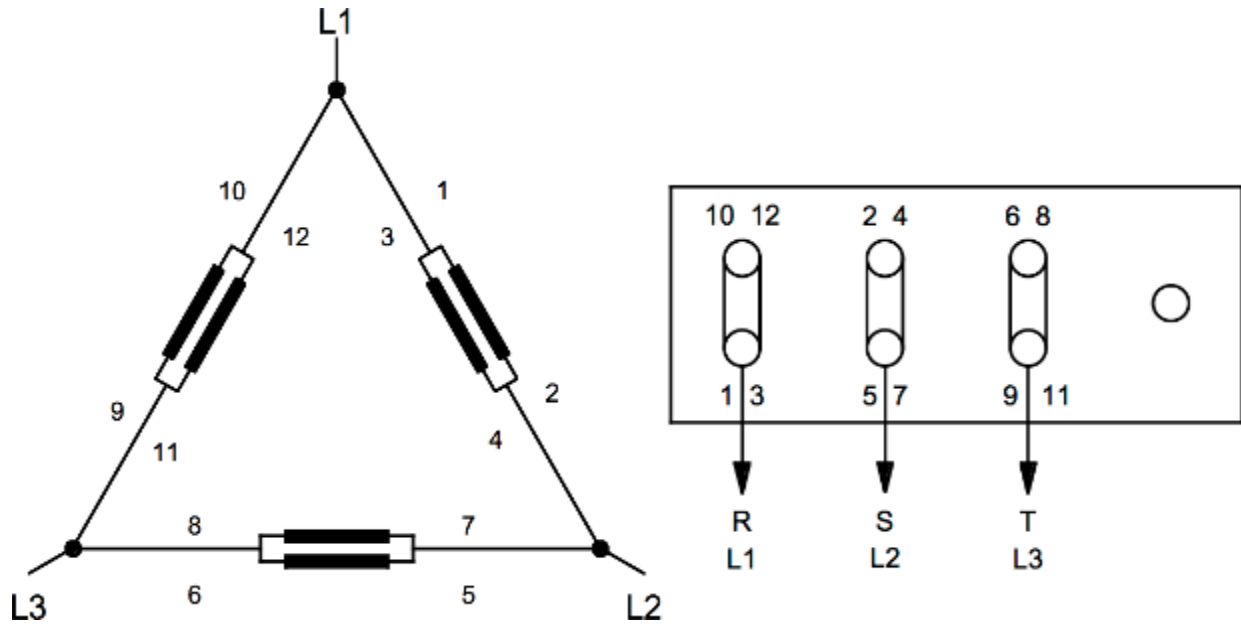

Legs	Voltage				
	50hz	110 3Φ	115 3Φ	120 3Φ	127 3Φ
L1-L2-L3	60hz	120 3Φ	127 3Φ	133 3Φ	139 3Φ
	50hz	110	115	120	127
L-L	60hz	120	127	133	139

Double Delta

50Hz: 115/230 VOLT, 1 PHASE
 60Hz: 120/240 VOLT, 1 PHASE

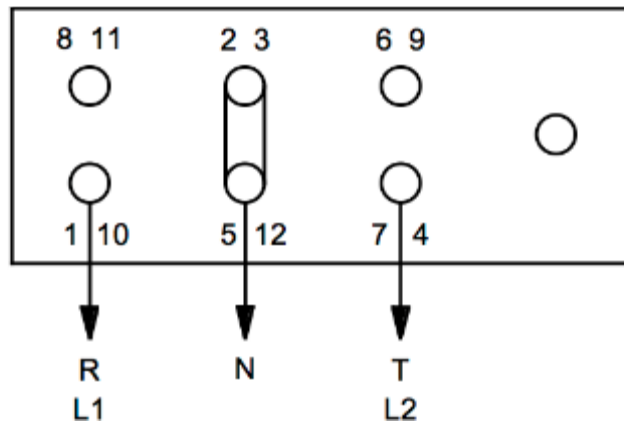
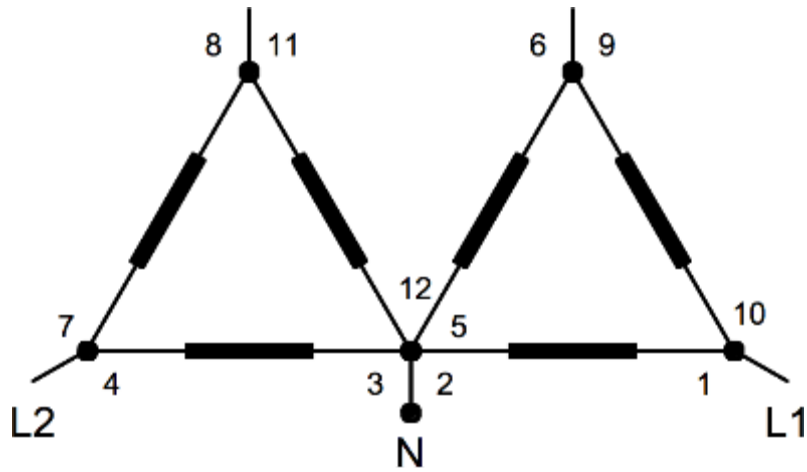

Legs		Voltages			
L-L	50hz	220	230	240	254
	60hz	240	254	266	277
N-L	50hz	110	115	120	127
	60hz	120	127	133	139

1 Phase Zig-Zag

50Hz: 115/230 VOLT, 1 PHASE
 60Hz: 120/240 VOLT, 1 PHASE

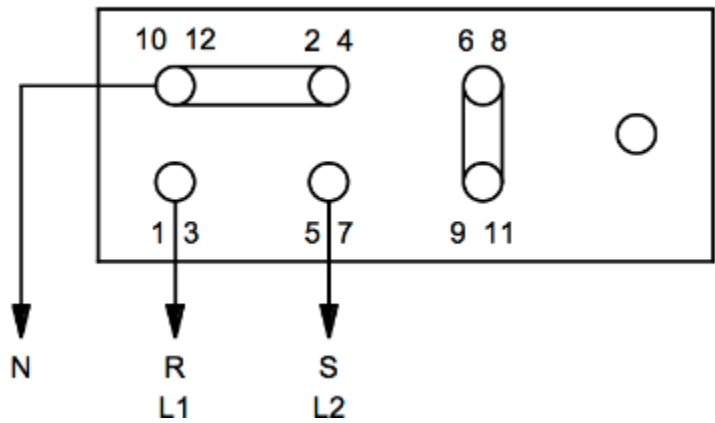
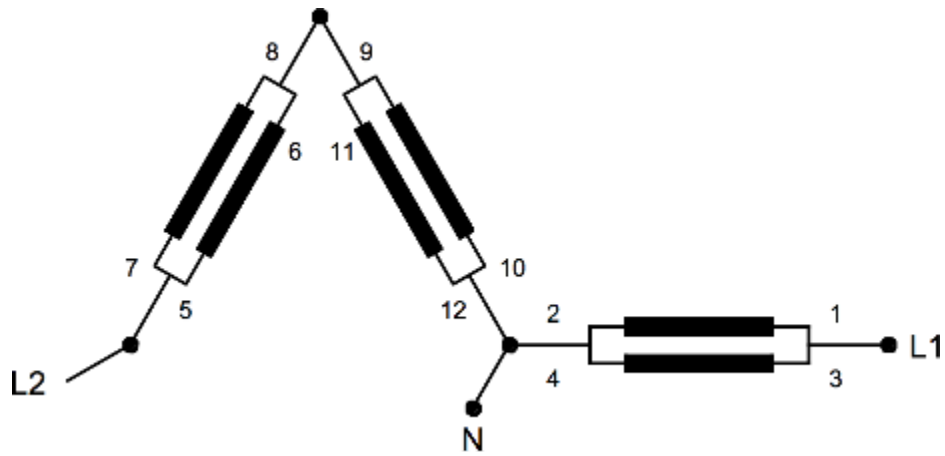

Legs	Voltages				
	L-L	50hz	220	230	240
	60hz	240	254	266	277
N-L	50hz	110	115	120	127
	60hz	120	127	133	139

Load Imbalance

While the maximum load imbalance for three-phase loads is not specifically stated in the relevant literature, it is generally accepted that three-phase motor loads are not tolerant of voltage imbalance of more than 2% between phases. Therefore, it is advisable to ensure that, when single-phase loads attached to a generator wired for three-phase current, the loads should be evenly distributed among each phase.

Automatic Voltage Regulator (AVR)



AVR Type DSR.

The Automatic Voltage Regulator (AVR) moderates the generator AC voltage and provides various protection mechanisms. Output voltage is adjusted by a potentiometer on the AVR board.

Note: The AVR senses voltage only on one leg. Please refer to the Mecc Alte Installers manual for further information

The manuals for the AVR are provided for the DSR model (Manuale_DSR_EN_rev05.pdf) and the SR7 model. Only the DSR type is currently used.

AVR Adjustment

This procedure should be performed if changing the stator wiring or if the voltage is outside of the desired range. In order to measure and adjust the voltage, the generator must be running at the target operating frequency and any load must be disconnected.

WARNING: *This procedure involves working near a high-voltage power source and should only be performed by a qualified technician.*



Location of the VOLT potentiometer

Measure the voltage from L1 to L2. Refer to the wiring chart to determine the proper terminals. Adjust the VOLT potentiometer on the AVR until the measured voltage is as desired.

Troubleshooting

Symptom	Possible Root Cause	Solution
Heavy load step causes frequency drop	High instant torque on engine	Adjust STAB pot (this will cause voltages to dip, but allow larger loads to be placed on the engine with minimized frequency impact). See Meccalte "regulators.pdf" for tuning method.
Low frequency while engine throttle is wide open	The load is above what engine/gasifier can support under current conditions	Improve gas quality. Reduce load.
Voltage is greater than +/- 5% from expected voltage.	VOLT needs adjustment	Take off the front panel of the generator to access the VOLT adjustment pot. Adjust accordingly, measuring voltage on legs with a volt meter.

**Please see the Mecc Alte Installers Manual for more troubleshooting.*